

<b>Number</b> <b>100-C12-S</b>	<b>Series</b> <b>CPS100</b> 100-C Half Male to Male Sloped Pro Plus 100
-----------------------------------	--

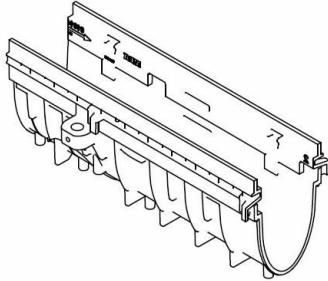

**100-C Half Presloped**

PART NUMBER	DIM "A"	DIM "B"	WEIGHT (LBS)
100C-12	6.5	6.5	4.6
100C01-12	7.6	7.7	6.2
100C02-12	7.8	7.9	6.3
100C03-12	8.0	8.1	6.4
100C04-12	8.2	8.3	6.5
100C05-12	8.4	8.5	6.5
100C05N-12	8.5	8.5	6.6
100C06-12	8.6	8.7	6.7
100C07-12	8.8	8.9	6.7
100C08-12	9.0	9.1	6.9
100C09-12	9.2	9.3	7.0
100C10-12	9.4	9.5	7.1
100C11-12	9.6	9.7	8.6
100C12-12	9.8	9.9	8.7
100C13-12	10.0	10.1	8.8
100C14-12	10.2	10.3	8.9
100C15-12	10.4	10.5	9.0
100C15N-12	10.5	10.5	9.1
100C16-12	10.6	10.7	9.1
100C17-12	10.8	10.9	9.2
100C18-12	11.0	11.1	9.3
100C19-12	11.2	11.3	9.4
100C20-12	11.4	11.5	9.5

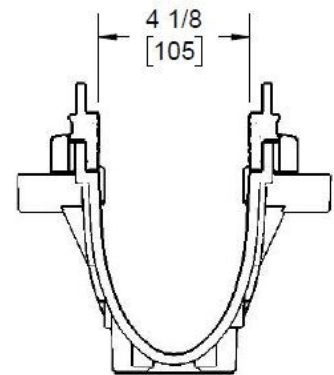
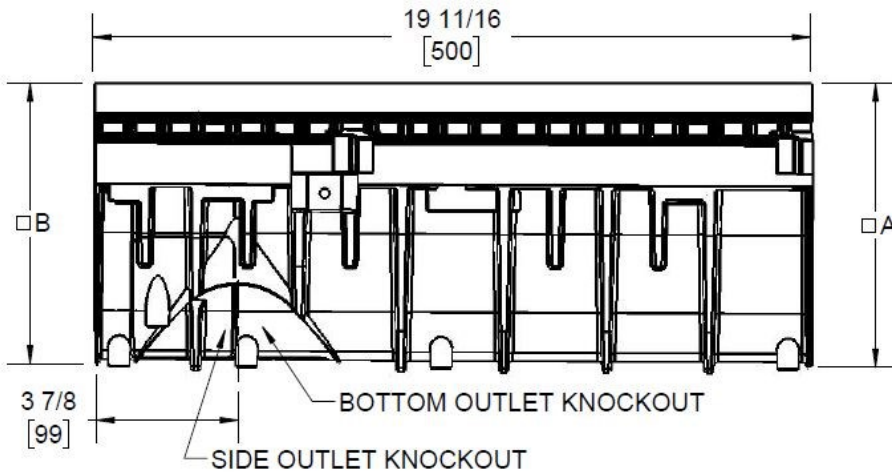
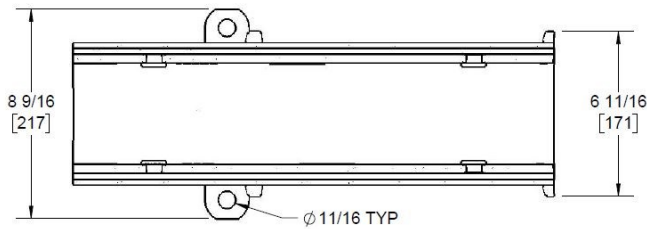

U.S. Patent No. 7,736,092

**Manufacturer**



**Specification**

JOSAM 100C-12 CHANNEL. 19.7" (500mm) LONG WITH 4" (102mm) INTERNAL WIDTH AND RADIUSSED BOTTOM. PRESLOPED CHANNEL. HALF METER MALE TO MALE ENDS, SUPPLIED BY TRENCH DRAIN SUPPLY.

DISCLAIMER - The customer and the customer's architects, engineers, consultants, and other professionals are completely responsible for the selection installation and maintenance of any product purchased from Trench Drain Supply and/or its manufacturers. TRENCH DRAIN SUPPLY MAKES NO WARRANTY, EXPRESS OR IMPLIED, AS TO THE SUITABILITY, DESIGN, MERCHANTABILITY, OR FITNESS OF THE PRODUCT FOR CUSTOMERS APPLICATION. The drawing and information provided remain the property and copyright of the manufacturer listed. The manufacturer reserves the right to modify specification without notice.